



Drill-Press Table

   **Caution:** To use this product safely, *always* follow the safety instructions that came with your power tool. As with any power tool accessory, *always* wear eye protection and hearing protection.

Attaching Mounting Plate to Drill Press

Mounting hardware is supplied for drill-press tables with through slots and those with blind T-slots.

Through Slots

1. Align the 3/4" center hole in the mounting plate with the center hole of existing table.
2. Insert T-bolts with flat washers in the recessed slots in the mounting plate and through slots in the table.
3. Install fender washers and hex nuts, and finger tighten.
4. Adjust mounting plate position on the table as needed.
5. Tighten the four nuts.

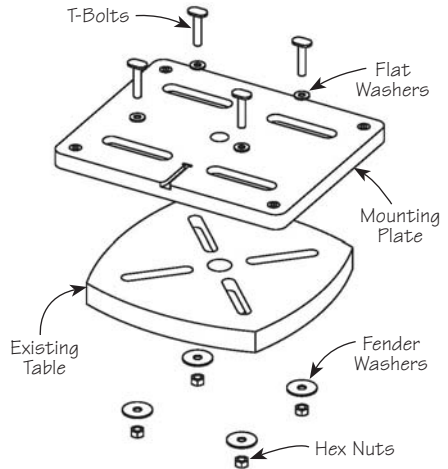

Blind T-Slots

1. Place a T-nut in each T-slot in the drill press-table such that they align with the slots in the mounting plate. This may involve some trial and error.
2. Align the 3/4" center hole in the mounting plate with the center hole of existing table.
3. Insert hex bolts with flat washers in the recessed slots in the mounting plate and into the T-nuts in the table.
4. Finger tighten the bolts.
5. Adjust mounting plate position on the table as needed.
6. Tighten the four bolts.

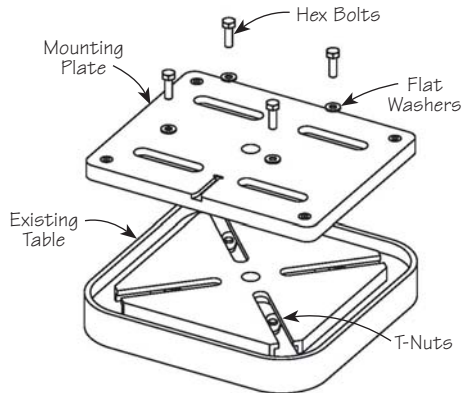

Attaching Table Top to Mounting Plate

Position the table top on the mounting plate and secure with four connector bolts using the 4 mm hex key.

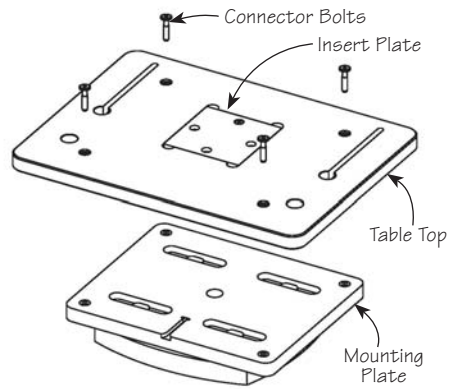

Insert Plate

The 4" x 4" insert plate helps to prevent blow out in the back of a workpiece. As the insert gets consumed, it can be rotated to three additional positions.

Replacement insert plates can be made from 1/4" thick plywood or MDF.

Levelling the Insert Plate

1. Loosen the machine screw using the 1/8" hex key.
2. Adjust the four levelling screws with the hex key, one corner at a time, as required to bring the insert plate flush with the laminate surface.
3. Once the insert plate is flush with the top, lightly tighten the machine screw.

Note: The 1/8" hex key is stored in a pocket just below the front edge of the top. A magnet at the bottom of the pocket keeps the hex key in place.

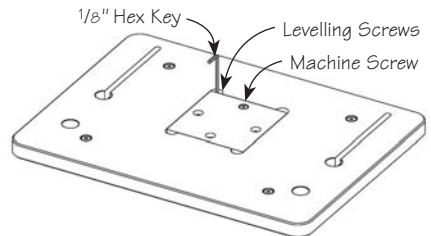
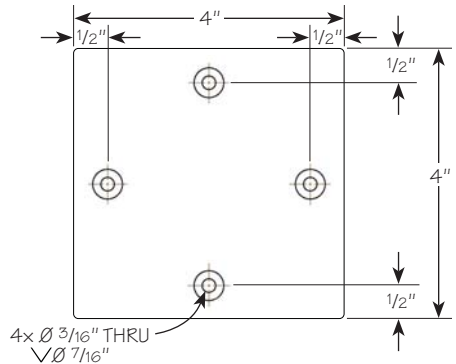

Installing the Fence

Secure the optional fence assembly onto the drill-press table top using two T-bolts, two flat washers and two knobs, as shown.

